

Premier DX200 & CF20

Centrifugal extract and condensation control fans

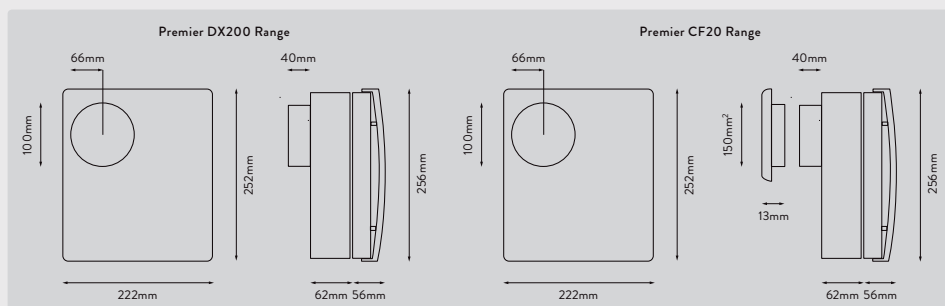

The Premier range of centrifugal fans is designed specifically for domestic applications including bathrooms, shower rooms, toilets and utility rooms where longer duct runs are required. All models have a gloss white casing with a clean and sleek appearance. A two-part casing means Premier fans can be recess or surface mounted.



Product Features	DX200	DX200T	CF20	CF20T
Product Codes	91013AW	91014AW	91015AW	91016AW
Condensation Control			✓	✓
Timer (adjustable 30s - 20m)		✓		✓
Pullcord (manual override)			✓	✓
Humidistat			✓	✓
Quick Visit Timer Delay (2mins)				✓
Room Size Selector			✓	✓

Product Selector		DX200	DX200T	CF20	CF20T
Product Codes		91013AW	91014AW	91015AW	91016AW
Speeds		2	4	4	4
Trickle Ventilation Facility			✓	✓	✓
Boost Ventilation Facility				✓	✓
Electrical Power Rating (W)		14/27	11/14/19/27	11/14/19/27	11/14/19/27
IP Rating		IPX5	IPX5	IPX5	IPX5
Weight (kg)		2.2	2.2	2.2	2.2
UK Guarantee (years)		2	2	2	2
Extract Performance (m ³ /h)	speed 3	•	100	100	100
	speed 2	100	84	84	84
	speed 1	59	59	59	59
	trickle	•	42	42	42
Extract Performance (l/s)	speed 3	•	28	28	28
	speed 2	28	24	24	24
	speed 1	17	17	17	17
	trickle	•	12	10	10
Sound Pressure (dBA@3m)	speed 3	•	42	42	42
	speed 2	42	37	37	37
	speed 1	28	28	28	28
	trickle	•	20	20	20

Performance for DX200

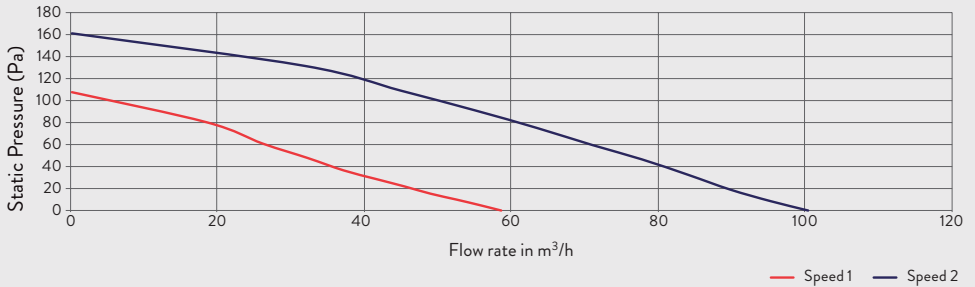

Performance for CF20

